

ROTHENBERGER

E-Z CUTTER®

E-Z CUTTER®



Instructions for use



CMS

Industrial Equipment Company

6112 N. Mesa St. #127, El Paso, TX 79912

Ph: 1-866-566-0222

Index

Operator Safety Instructions	3	Parts for Serial Number 5851 and Below	9
Specifications	4	Maintenance Instructions	10
Standard Equipment	5	Lubrication	10
Accessories	5	Cutter Wheel Alignment	10
Preparing for Operation	6	Motor Brushes	10
Installation.....	6	Cutter Wheel Sharpening	10
Power	6	Maintenance Record	11
Pipe Support System	6	Assemblies	
Operating Instructions	8	E-Z Cutter Main Assembly.....	12
Cutter Wheel Replacement	9	Parts List	13
		E-Z Cutter Motor & Gearbox Assembly.....	14
		Parts List	15

ORDERING SPARE / REPLACEMENT PARTS

Manufacturing part numbers shown throughout this manual. To order spare parts, please use part numbers from the enclosed separate parts list.

Collins, Collins E-Z Cutter, and E-Z Cutter are trademarks of Rothenberger.

Operator Safety Information

This E-Z Cutter is designed for cutting pipe and tubing as specified. To accomplish the cutting function requires dexterity and mechanical skills as well as sound safety habits.

Although this machine is manufactured for safe, dependable operation, it is impossible to anticipate those combinations of circumstances which could result in an accident. The following instructions are recommended for safe operation of the machine.

The operator is cautioned to always practice "Safety First" during each phase of use, including setup and maintenance of this unit.

- 1. Read and understand the Instruction Manual.** Before operating or performing maintenance on this machine, read the operator's manual carefully. Become familiar with the machine's operations, applications and limitations. Be particularly aware of its specific hazards. Store the operator's manual in a clean area and always at a readily available location. Additional copies are available for a nominal charge.
- 2. Inspect the equipment.** Prior to starting the machine, check the movable parts for obstructions such as rags, packing remnants, etc. Be sure that guards and machine parts are properly installed and secured.
- 3. Ground the machine.** The machine power cord includes a plug with a ground connector. Be certain the machine is connected to an internally grounded electrical system.
- 4. Keep the work area clean.** Keep the work area adjacent to the machine clear of clutter for unobstructed movement of the operator.
- 5. It is mandatory to use a pipe/tubing support system with the Collins E-Z Cutter.** (See pages 6 and 7 for suggested systems.)
- 6. Wear proper clothing.** Loose clothing can get easily entangled in moving parts. When operating the machine, do not wear unbuttoned jackets, loose sleeve cuffs, neckties, long hair, etc. Safety glasses and shoes should be worn.
- 7. Secure machine and work.** Make certain that the machine is bolted to a heavy work bench or proper stand.
- 8. Always maintain machine.** Keep machine clean and cutting tools sharp for safe, dependable operation. Follow lubricating instructions. Report any unsafe condition for immediate correction.
- 9. Keep alert.** Do not operate machine if ill or drowsy from medication or fatigue. Avoid horseplay around equipment and keep bystanders a safe distance from equipment.
- 10. Operate on switch side only.** Machine should be operated on switch side only. Never reach across moving parts or material being worked on. On/Off Switch should always be accessible to operator.
- 11. Operate in proper environment.** Machine should not be operated in damp locations. Wear hearing protection in noisy shop environments. Ensure of proper illumination in work area.
- 12. Do not misuse machine.** Perform only the functions for which the machine is designed. Do not force machine.
- 13. Disconnect power cord prior to servicing.** Repair should be attempted only by authorized personnel. Always disconnect power cord before making any adjustments or servicing the machine.
- 14. Keep visitors away.** All visitors should be kept at a safe distance from work area.
- 15. Use recommended accessories only.** Refer to Operator's Manual. Use of improper accessories may be hazardous.

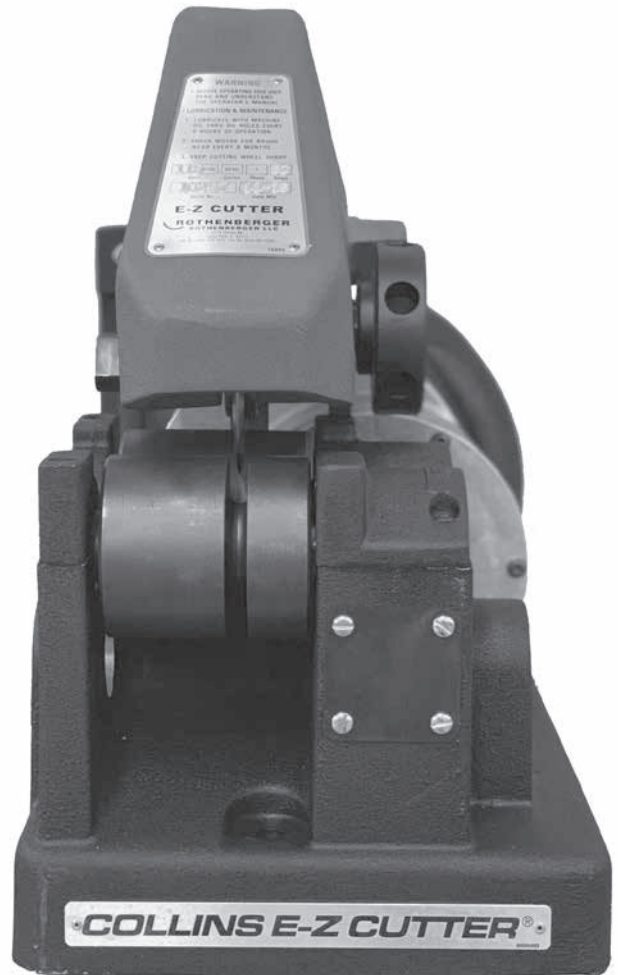

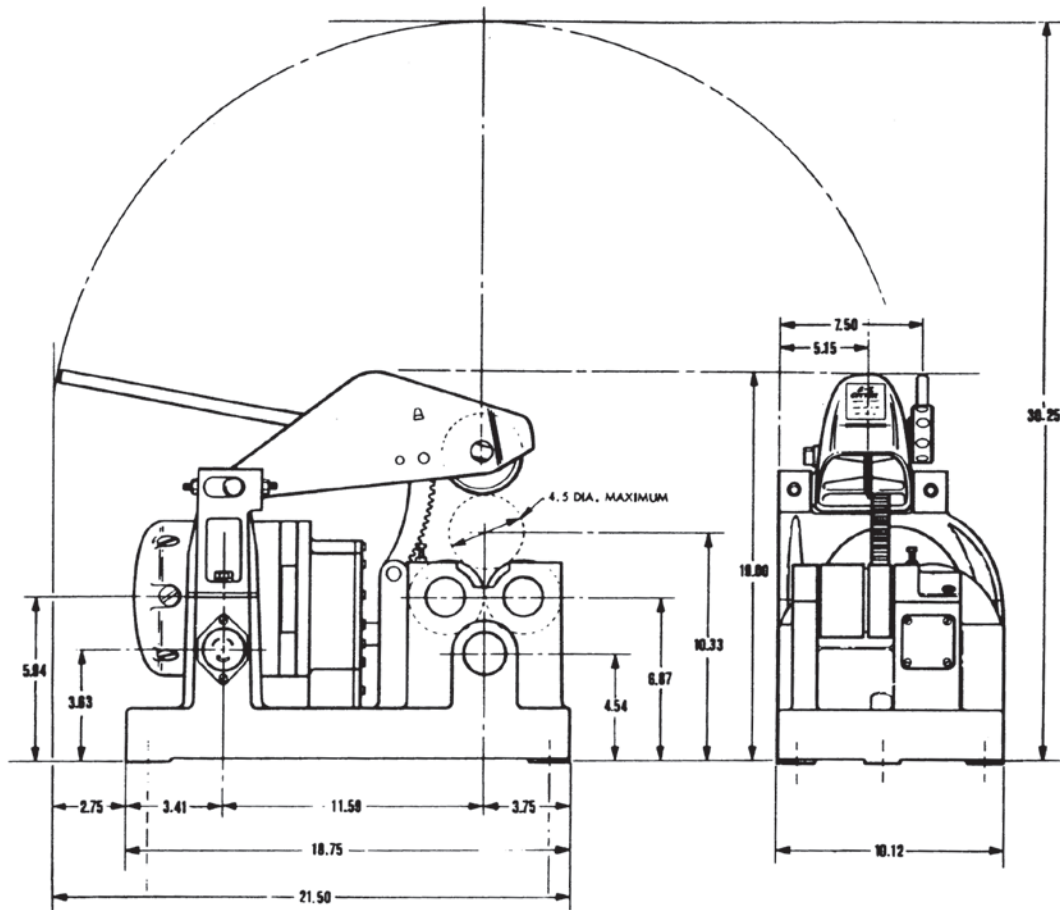

Specification

Material	Material Diameter	Wall Thickness	Recommended Blade
Galvanized pipe	1/4" - 3" I.D.	Schedule 10-80	03224
Black iron pipe	1/4" - 3" I.D.	Schedule 40-80	00535
Steel tubing pipe	5/8" - 3 1/2" O.D.	1/32" - 5/16"	03225
Plastic pipe	1/4" - 4" I.D.	Schedule 80	03231
Copper tubing	5/8" - 3 1/2" O.D.	1/32" - 5/16"	03225
Aluminum tubing	5/8" - 3 1/2" O.D.	3/32" - 1/4"	03225
Stainless Steel (316 S.S.)	5/8" - 2 1/2" O.D.	1/32" - 5/16"	03225

Cutting Capacity:

The factory recommends using the E-Z Cutter only for the material specified above. Cutting of material not specified above may be possible, however. Please contact the factory for an evaluation of the E-Z Cutter's capability to cut the material in question. Using the E-Z Cutter on material not listed above or not approved, voids the machine's warranty.

Motor

- Single phase
 - a 115 V. 50/60 Hz, 15 Amps., 1/2 H.P., 6 brush universal type
 - b 230 V. 50/60 Hz, 8 Amps, 1/2 H.P., 6 brush universal type.

Switch

Foot switch — on/off, heavy duty, oil and water tight, with safety guard.

Gear Box

Motor Gear Box — helical heat treated steel gear construction
 Roller Gear Box — helical heat treated steel gear construction

Roller Speed

Free Running..... 403 RPM
 Under Load..... 375 RPM

Cutter Wheels..... High Speed Tool Steel

Noise Level..... 84 dB max. ("A" scale, slow response)

Shipping Weight 125 LBS

Standard Equipment

The Collins E-Z Cutter (00032) comes complete with heavy duty foot switch and cutter wheel. Two roller supports and two stationary supports are included in #00033.

Accessories

Cutter Wheel with Bearings

- Pipe cutter wheel..... #00034
- Tube cutter wheel..... #00035
- Soil pipe cutter wheel..... #00035

Roller Bearing Pipe Support..... #00069

- Weight..... 4 lbs.
- Dimensions..... 5½ x 5 x 2"

Stationary Support..... #00036

- Weight..... 3 lbs.
- Dimensions..... 6⅛ x 5⅞ x 1½"

Pipe Support Fitting..... #00071

- Weight..... 3 lbs.
- Dimensions..... 4½ x 4¾ x 2"
- Accepts 1¼" steel pipe through support hole and 1" steel pipe for legs.

E-Z Cutter Stand..... #00037

- Weight..... 42 lbs.
- Dimensions..... 30 x 17 x 27"

Foot Switch (115 V)..... #00079

- Weight..... 8 lbs.
- Dimensions (packed)..... 10 x 5 x 6"

Foot Switch (230 V)..... #02350

- Weight..... 8 lbs.
- Dimensions (packed)..... 10 x 5 x 6"



STATIONARY
SUPPORT
#00036



PIPE SUPPORT
FITTING
#00071



E-Z CUTTER
STAND
#00037

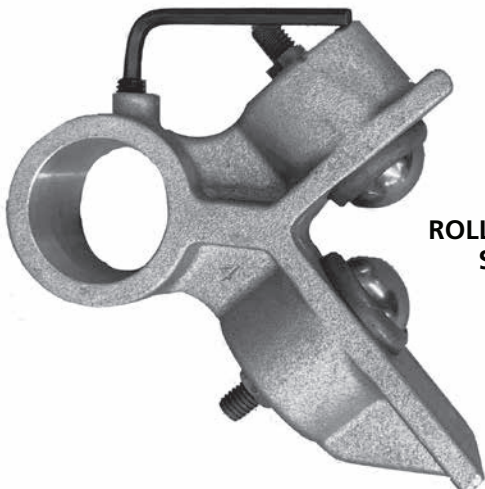

ROLLER BEARING
SUPPORT
#00069

FOOT SWITCH
#00079



Preparing for Operation

Installation

Your E-Z Cutter may be mounted on a bench or on the E-Z Cutter Stand (#00037) which is available as an accessory.

Bench Mounting: Ensure that the E-Z Cutter is mounted on a bench sturdy enough to support the E-Z Cutter's weight and the pressure generated by normal cutting operation. The E-Z Cutter should be bolted solidly to the bench with 1/2" diameter bolts. Bolt the unit at the approximate location relative to your pipe support system (see next pages).

E-Z Cutter Stand Mounting: Ensure that the E-Z Cutter is bolted securely to the stand with 1/2" bolts and that the machine is placed on a level area and bolted to the floor with 1/2" studs after you have established your pipe support system.

Power

Use proper electric current as shown on name plate. To prevent power loss, extension cord of sufficient capacity must be used.

To avoid electrical shocks when operating in the field, connect the ground wire of the extension cord.

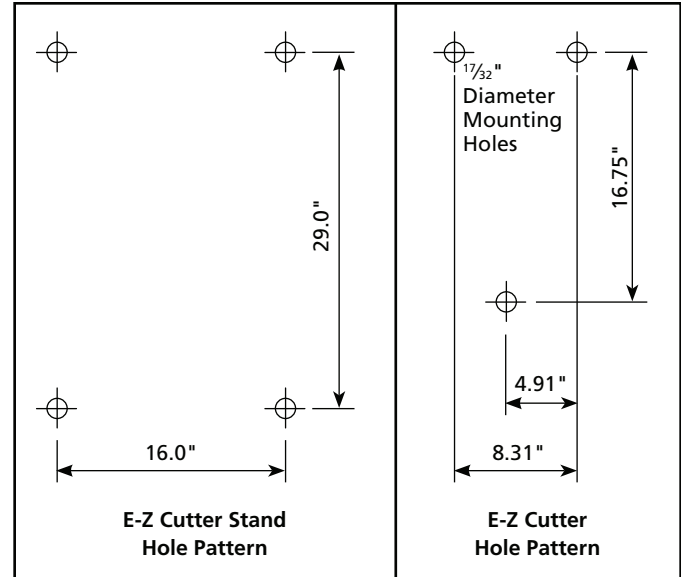

Power	Cord Length	Wire Size
115 V	Below 50' 50'-100'	12-3 10-3
230 V 1 Phase	Below 50' 50'-100'	14-3 12-3

Installation of Your Pipe Support System

Your E-Z Cutter combined with the appropriate Collins accessories can put your company into production cutting of pipe and tubing quickly.

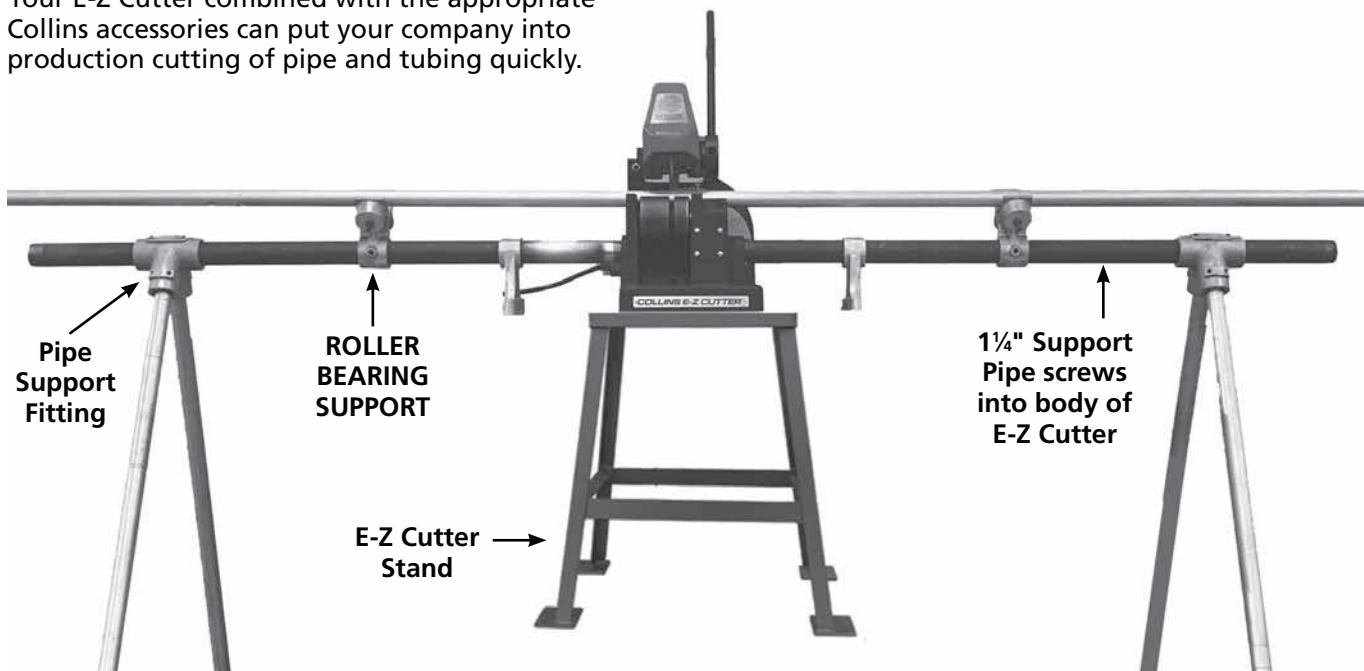

E-Z Cutter Bench Mounting: There are two tapped holes on either side of the E-Z Cutter that will accept 1 1/4" NPT threaded pipe. By securing a length appropriate to your needs of 1 1/4" pipe into the sides of the unit, you can establish a support base as long as required. The 1 1/4" pipe is maintained stationary and level by the Collins Stationary Support (#00036). Two 3/8" bolts or screws are needed to secure the Stationary Support to the bench.

Select either the heavy duty ball bearing support or light duty roller-type support for your feed system. It is best to space the supports every 5'. All supports go easily on the 1 1/4" pipe and are held stationary by a thumbscrew.

E-Z Cutter Stand Mounting: You can make your own pipe support system for a stand mounted E-Z Cutter. You will need 1" pipe, pipe support fittings and Collins roller bearing supports. The number of accessories you require will depend on your individual needs.

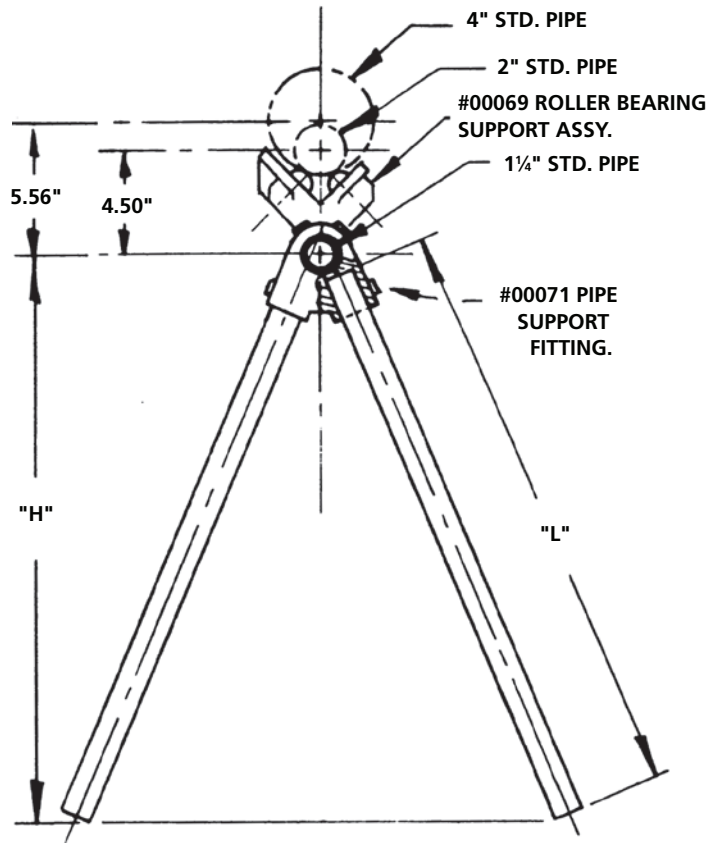
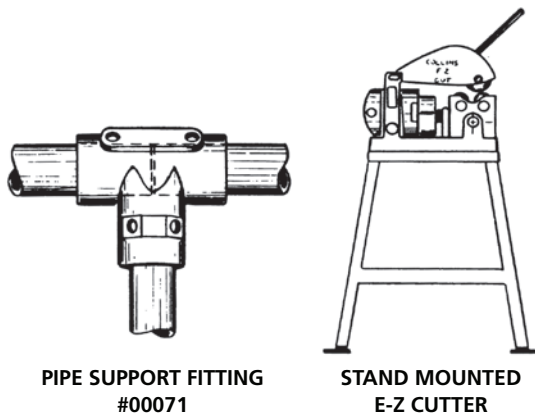

1. Determine height "H" required and cut 1" standard pipe to length "L" shown in table below.
2. All dimensions are in inches.

Follow the steps below to set up your pipe support system.

1. Measure the height from the center of the E-Z Cutter Pipe Support mounting hole to the ground.
2. Using the table to the right, determine the length of the 1" pipe support legs.
3. After cutting the legs to the desired length, put a rubber mounting pad at one end of the pipe and insert the other end into the #00071 pipe support fitting. Tighten the attaching screws.
4. Slide two heavy duty roller bearing supports onto a 10-foot length of 1 1/4" standard pipe. At the non-threaded end of the pipe, mount the pipe support fitting. Do not tighten the attaching screws until the threaded pipe end is installed in the mounting hole of the E-Z Cutter base.
5. The heavy duty roller supports should be located a maximum of five feet apart.
6. There are four attaching screws on the fitting which allow an extra support section to be coupled in the fitting.

"H"	"L"	"H"	"L"
40.5	42.94	32.0	33.69
40.0	42.37	31.5	33.19
39.5	41.87	31.0	32.62
39.0	41.31	30.5	32.06
38.5	40.75	30.0	31.50
38.0	40.25	29.5	31.00
37.5	39.69	29.0	30.44
37.0	39.12	28.5	29.87
36.5	38.56	28.0	29.37
36.0	38.06	27.5	28.87
35.5	37.50	27.0	28.25
35.0	37.00	26.5	27.75
34.5	36.37	26.0	27.19
34.0	35.87	25.5	26.62
33.5	35.31	25.0	26.06
33.0	34.75	24.5	25.50
32.5	34.25	24.0	25.00

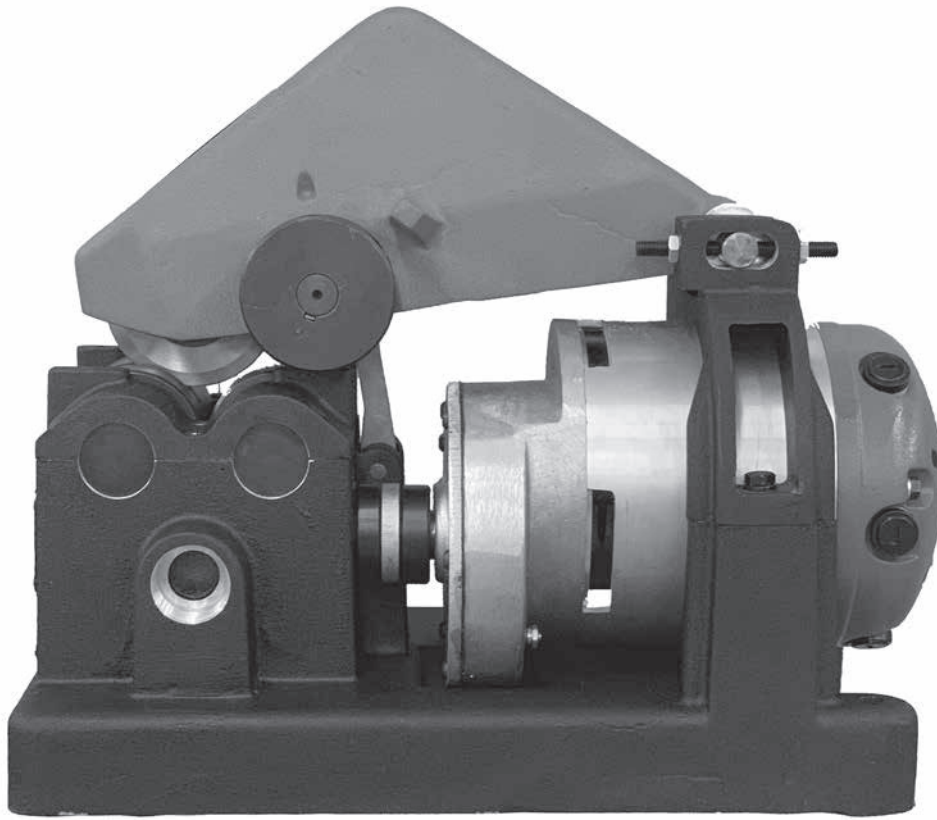

Operating Instructions

WARNING: Do not wear gloves, rings, or loose clothing while operating the E-Z Cutter. Remove all burrs from material to be cut.

1. Before making electrical connection, set the E-Z Cutter for the material you intend to cut:
 - (a) Lift the head casting with feed wheel bar removed from the sprocket.
 - (b) Feed the material underneath the cutter wheel.
 - (c) Lower the head casting until the cutter wheel rests on the material to be cut.
 - (d) Put the feed wheel bar into the appropriate sprocket that allows you to pull down comfortably through the material.
 - (e) Push feed wheel bar back towards the motor until it stops against the rest of the head casting.
2. Make electrical connection: (Voltage of outlet must be the same as voltage indicated on the tag and name plate.) Put twist lock plug into side of E-Z Cutter, position safety foot switch and plug into proper outlet.

3. While E-Z Cutter is off, feed material with left hand to desired cut off location underneath cutter wheel. Bring cutter wheel down with feed wheel bar so it rests easily on your cut off mark and apply slight pressure on the feed wheel bar.

4. Remove left hand from material.
5. Turn machine on with foot switch. Power driven rollers will rotate pipe.
6. Pull down on feed wheel bar until material is cut. Do not force the cut, let the machine do the work.

WARNING: Ensure you have the proper support for the cut material.

7. After material is cut, lift head casting by pushing back on feed wheel bar while turning off machine.

WARNING: Do not grasp rotating stock.

8. After stock stops rotating, feed again and repeat process.

Cutter Wheel Replacement

1. Rotate head casting to full back position.
2. Use appropriate sized adjustable wrench and turn cutter wheel shoulder screw counter clockwise. As you withdraw shoulder screw from head casting, remove wheel as it is released from shoulder screw.
3. Replace cutter wheel by positioning cutter wheel in the head casting over hole for shoulder wheel screw. Insert shoulder screw and tighten with adjustable wrench.

NOTE: If you choose to buy a cutter wheel without a bearing it will be necessary for you to remove the bearing from your existing wheel and press it into your new wheel. Ensure that you use only a Collins #R04201428R bearing.



Head casting in full back position

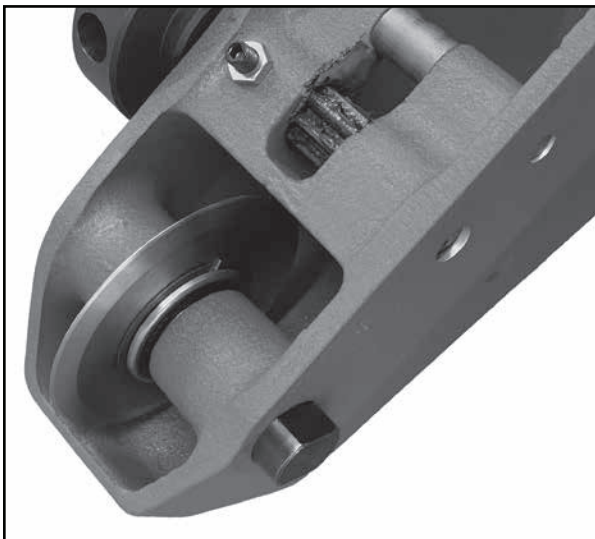

Positioning cutter wheel

Parts for E-Z Cutters with Serial Number 5851 and Below

NOTE: The parts listed in this catalog can be used on all Collins E-Z Cutters. However, some parts on earlier model E-Z Cutters have been replaced or modified. If you have an E-Z Cutter with a serial number of 5851 or lower please read and follow the instructions below regarding replacement parts.

Foot Switch Assembly

For machines prior to Serial #5851:

Replace #3366 foot switch assembly with #00079 (115 V.) or #02350 (230 V.) foot switch assemblies. In addition to this, the male receptacle connector #3372 must be replaced with #R0420218R (115 V.) or #R0420219R (230 V.) receptacle.

For machines prior to Serial #5000:

Replace #3044 rack gear and/or #3213 pinion gear-shaft with #R04203444R rack gear and pinion conversion kit since individual parts are not interchangeable. This conversion kit includes the following parts:

- #R04201448R guide roller (replaces #3219)
- #R04201449R gear rack (replaces #3044)
- #R04201450R pinion gearshaft (replaces #3213)
- #03220 guide roller pin (replaces #3220)
- #R04201268R Woodruff key (replaces #1385)
- #R04201238R rack gear pin (replaces #3045)

Rollers

For machines prior to Serial #5645 (October 1974):

Although the #3019 grooved roller and the #3021 smooth roller can be directly replaced with the new #R04201776R grooved roller and the #R04201777R smooth roller, since the old #3024 grease retainer felt, it is recommended that the #3024 grease retainer felt also be replaced with the #R04201837R Seal Bushing and the #R04201849R "O"-ring seal for better grease retention. Order one seal bushing and one "O" ring seal per roller.

Base, Motor Yoke and Bearing Caps

For machines prior to Serial #5645 (October 1974):

If any one of the #3012 base, #3013 motor yoke, #3054 R.H. bearing cap or #3055 L.H. bearing cap needs replacement it is recommended that the complete #R0421846R base assembly be ordered. This base assembly includes the following parts:

#R04201014R	2	Screw, hex, hd. cap, 3/8"-16 x 1 1/4"
#R04201123R	2	Screw, soc, hd. cap, 5/16"-18 x 1 1/2"
#R04201121R	2	Screw, soc, hd. cap, 5/16"-18 x 1"
#R04201775R	1	Cap, bearing, left hand
#R04201846R	1	Base

Maintenance

Lubrication Instructions

Motor Gear Case: It is lubricated permanently and requires no periodic lubrication. The lubrication oil used in the motor gear case is SAE 90.

Roller Gear Case: It is packed with grease and sealed, and requires no periodic lubrication. If service is required, replenish lubricant with Moly-Shield ST-200 or equivalent.

We now recommend using a heavy grease on the gear rack and when that starts getting dry or gritty, wipe the old grease off and reapply fresh grease. We suggest using a small paint brush to do this and AMSOIL High-Viscosity Lithium Complex Grease P/N GVCCR-EA available following this link:

<https://checkout.square.site/buy/YO4ZBBDKBIOA6Q5OA7TBWLE5>

Motor: Requires no lubrication. All ball bearings are sealed.

Cutter Wheel Alignment

Your E-Z Cutter wheel is aligned professionally by our factory assemblymen prior to its shipping. If for some reason your E-Z Cutter becomes out of alignment, you will observe that the wheel is not cutting but making thread marks on your stock.

To align the E-Z Cutter, loosen the appropriate head aligning set screws and adjust the head to the right or left as required. Tighten the set screws once the wheel is aligned.



E-Z Cutter as seen from rear

Motor Brushes

Check motor for brush wear every six months. If motor lacks power due to a dirty commutator, use a commutator cleaner stick or fine emery cloth.

Cutter Wheel Sharpening

If you have resharpening capability locally, the following drawings are provided for your convenience.

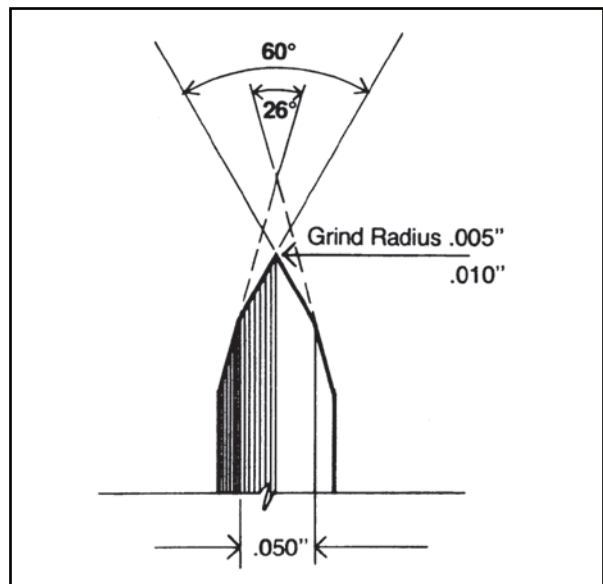

Pipe Cutter Wheel #00034

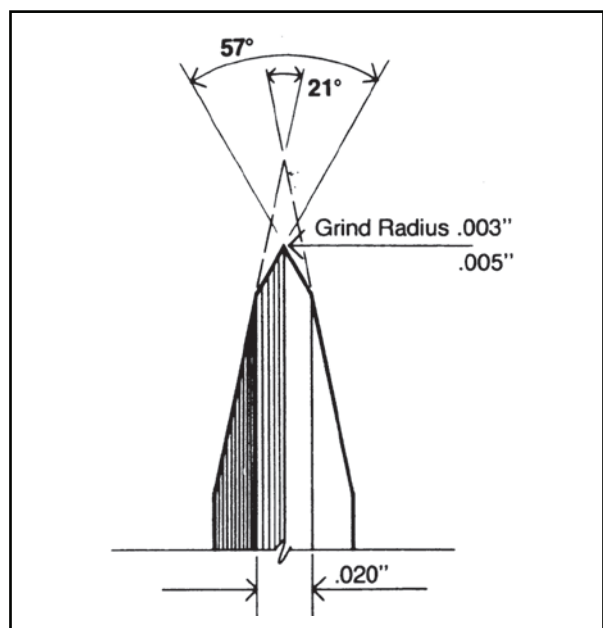

Tube Cutter Wheel #00035

